

Success Story

Saratov State University Professor Designs UHF Antenna Amplifier Using NI AWR Software



“NI AWR software is a powerful EDA tool capable of simulating a complete functional device inclusive of microstrip layout. The intuitive user interface and efficient optimization engine were key to the success of this project.”

Alexander Khvalin and Alexey Vorobiev, Saratov

Company

Saratov Chernyshevsky State University (Saratov) is a higher education and research institution in Russia. The university was founded in 1909 and is located on the Volga River in the city of Saratov. The university has 28 departments, more than 90 programs of study, and enrollment of about 28,000 students.

Challenge

Most published papers describing the design flow for RF power amplifiers (PAs) lack information regarding exact solutions. Alexander Khvalin, professor at Saratov, co-authored with student and now RF engineer Alexey Vorobiev a paper describing the development of a design method based on structural and parametrical optimization that would enable designers to achieve enhanced characteristics.

Structural synthesis for the amplifier would involve addition of the necessary matching elements. The active device of choice was the Vishay Semiconductor’s bipolar junction transistor (BJT) BFR90, which was modeled according to the Gummel-Poon model-based method. Parametrical synthesis was confined to the solution of optimization problems, which meant achieving maximum gain and minimal voltage standing-wave ratio (VSWR) at both input and output in the operating bandwidth.

Solution

The designer used the NI AWR Design Environment platform to model the amplifier in the 0.3-0.8 GHz frequency range because of its ease of use and the ability to use electromagnetic (EM) documents and schematics in one project. The design of the amplifier was based on the two-stage antenna amplifier for decimeter-wave TV signals, which allowed for the maximum gain of 20 dB in the 0.3-0.8 GHz band. Figure 1 illustrates the schematic of the amplifier.

At-A-Glance	
Application	▪ Amplifier
Software	▪ NI AWR Design Environment ▪ Microwave Office ▪ AXIEM
Benefits	▪ Ease of use ▪ Co-simulation ability ▪ Proficient support services ▪ Career development

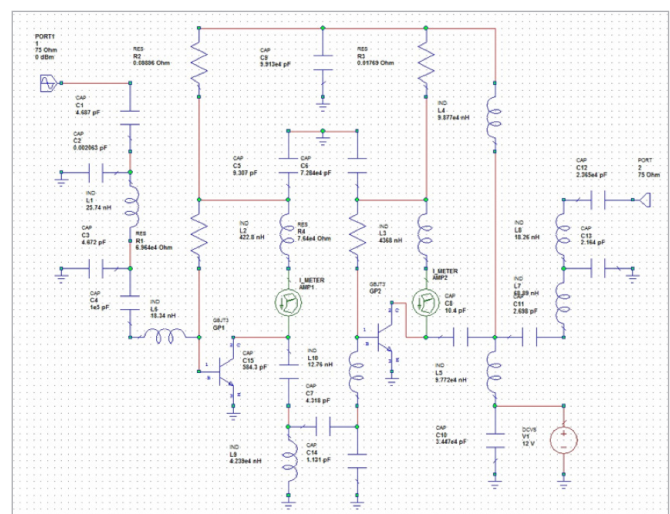

Figure 1: Circuit schematic of the proposed amplifier model.

As shown in the schematic, two BFR90 transistors are in the common emitter mode, and the collector current does not exceed 25 mA. Input and output networks are not symmetrical and are matched to the 75-ohm coaxial connector. Port 1 is driven with a harmonic signal and Port 2 is loaded with 75 ohms. The bias network (not shown) connects the amplifier to +12 V DC supply via capacitor C10 and RF choke inductor L5.

In order to achieve the gain of 30 ± 1 dB (VSWR<1.5) several structural changes had to be made. Parametrical synthesis was performed by variation of capacitances, inductivities, and resistances of the elements used. These values were optimized using several methods present in the software; utilization of more than one method enabled better efficiency of the optimization process. The most efficient combination comprised random, differential evolution and simplex algorithms.

Figure 2 shows the gain of the optimized amplifier, which is indeed 30 ± 1 dB in the operating bandwidth. Figures 3 and 4 present the input and output voltage standing wave ratio (VSWR) respectively. It is shown that the VSWR does not exceed 1.5 in the frequency range from 0.3 to 0.8 GHz.

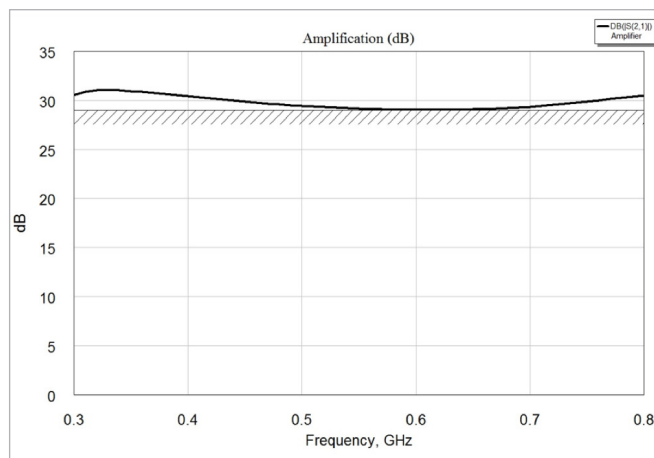

Figure 2: Optimized gain versus frequency.

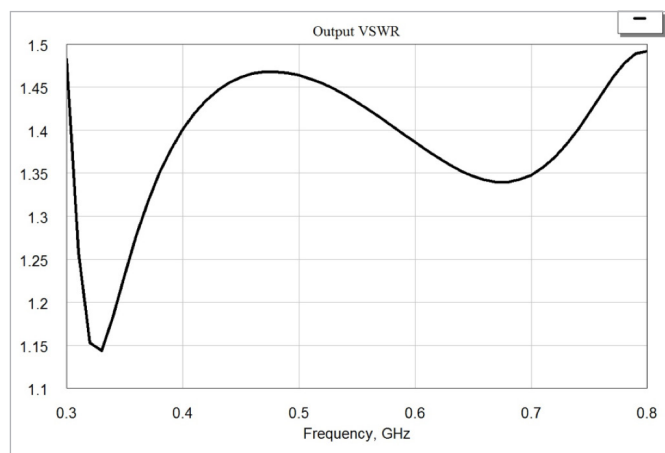

Figure 3: Input VSWR vs. frequency.

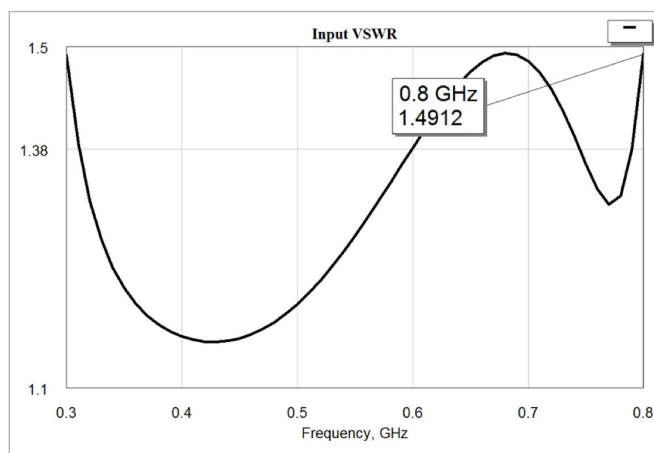

Figure 4: Output VSWR vs. frequency.

Table 1 compares the proposed amplifier to other commercially-available UHF antenna amplifiers.

Model	Frequency range, MHz	Gain, dB	DC supply, V	Vendor
La-32U	470-862	20±2	+5	Locus
БРИЗ-1.1	470-862	10-15 (adjustable)	+12	PLANAR
AWS-20	470-790	30	+12	Poland
Saratov State University	300-800	30±1	+12	n/a

Table 1: Proposed amplifier compared to other commercially-available UHF antenna amplifiers.

Conclusion

The design method of creating a model of the UHF amplifier based on BFR90 BJTs in order to solve structural and parametrical optimization problems was proved to be efficient, resulting in 30 ± 1 dB gain and VSWR<1.5 in the operating bandwidth from 0.3 to 0.8 GHz. The comprehensive documentation, technical support, and ability to consult with specialists, as well as the extensive element library and vast list of example projects in NI AWR software were key in the success of this senior thesis project. Khvalin feels that his experience using the software as a professor has been important in his success working as an engineer.